



NMEA 2000
NMEA 0183

Table of contents

Disclaimer	3
Installation Kit	4
Before installation	5
Proper Interceptor installation in transom	5
Interceptor Installation	6
Indirect Installation	7
FW Series Interceptor and Anode Mounting and Coating Instructions	9
Spare Parts List	10
Warranty Conditions	11
Registration	12

Disclaimer

The interceptor units are also steering equipment and it is the sole responsibility of the navigator-operator to ensure that, at any point, any problem that will alter the boat's course, rising from malfunction of interceptors, should be dealt immediately by the operator. At no circumstances, fault of our interceptor equipment leading to any kind of accident, creates liability for the manufacturer.

Trademark Notice

Hydrotab is a registered trademark of Olympic Engineering Ltd, Greece. All other trademarks, trade names or company names referenced herein are used for identification only and are property of their respective owners.

Patent Notice

The Hydrotab products are protected by patents and industrial design patents, patents pending or design patents pending.

Declaration of conformity

This product conforms to the following Electromagnetic Compatibility (EMC) regulations and standards for use in marine environments.
CE EN 60945

Technical information and Documentation

The technical information provided in this document was accurate and correct at the corresponding production time of the Hydrotab interceptors. Our operating principal for improving the manufactured product, may lead to changes regarding its specifications without prior notice. Liability will not be accepted for any inaccuracy considering the product and the user manual.

Fair use statement

This manual can be printed or copied for your own use only. Copies should not be provided to third parties and manual should not be commercialized.

Product Disposal

Waste removal of this product must be according to the Waste Electrical and Electronic Equipment (WEEE) Directive.

Product Registration

Please register your product online in order the warranty to be valid.

Installation Kit

1. Two Inteceptors

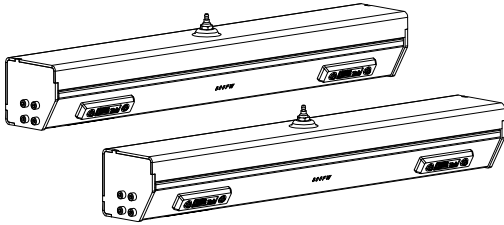

2. Fittings

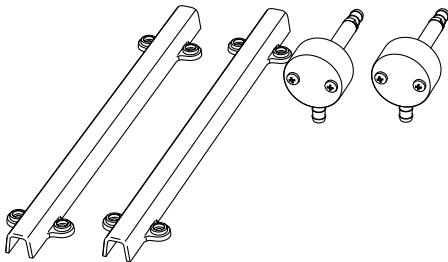

3. Interceptors' Drilling pattern

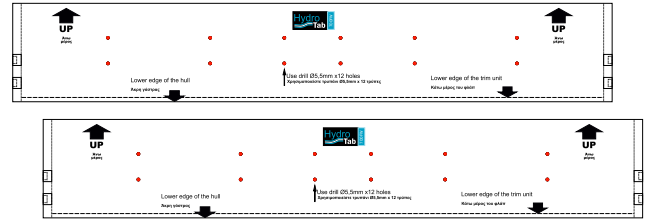

4. Screws



Interceptor mounting screws (6,3x32)



Fitting mounting screws (4,8x25)



Fitting mounting screws (4,2x18)



Washers M6

5. 7m piping

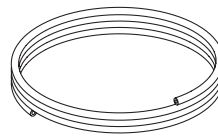

Required Tools for Installation

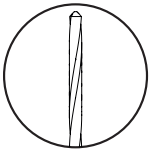

Drill Ø3

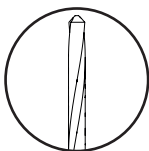

Drill Ø4

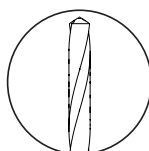

Drill Ø5,5

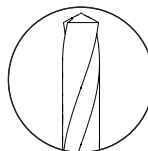

Drill Ø12

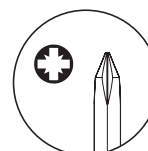

Screw driver



Allen Key N 05

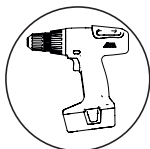

Drilling Tool



Sikaflex Gun

Before Installation

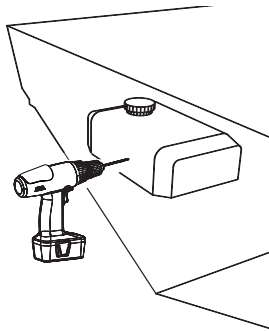

Make sure there are no obstructions behind the drilling area (tanks, fuel lines, cabling) which can be damaged or prevent the installation procedure.

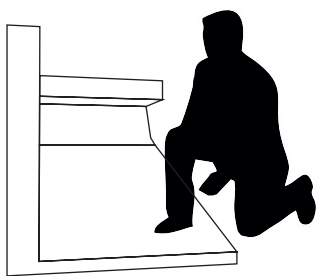

Attention! Make sure that the pipe insertion hole is accessible from the engine room.

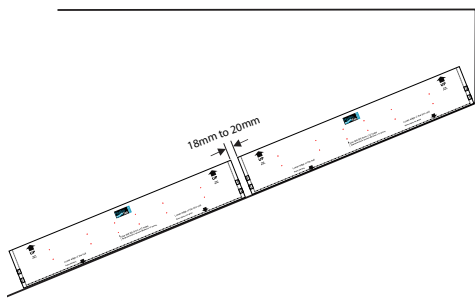

If there is a double installation on the boat, please allow a 18 to 20 mm space between them. (Figure 2)

Safety Precautions

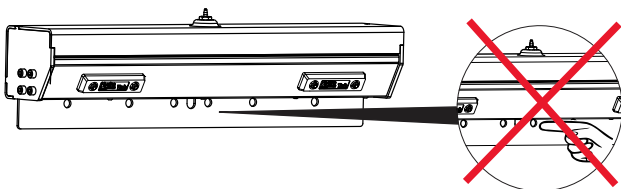

1. Place air unit in a dry space free of flammable or explosive gas
2. For high speed boats, over trim may cause unexpected turn.
3. Improper use of the trim tabs, may result to accident or injury.
4. **DO NOT PLACE YOUR FINGERS INSIDE THE BLADE HOLES**

Proper Interceptor installation in transom

Right

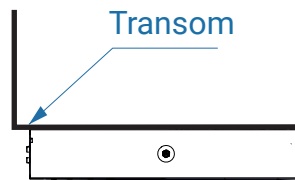

Wrong

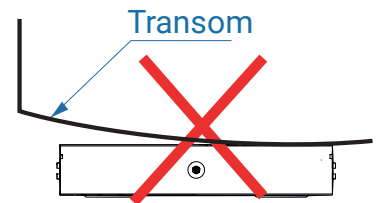

If the boat's transom has a significant curvature, it is necessary to create a flat plane for the installation. Acceptable flatness tolerances: 2mm.

For aluminum hulls, it is suggested Isolation Plates between hull and interceptors to be installed. You can find installation instructions in the Isolation Plates Kit.

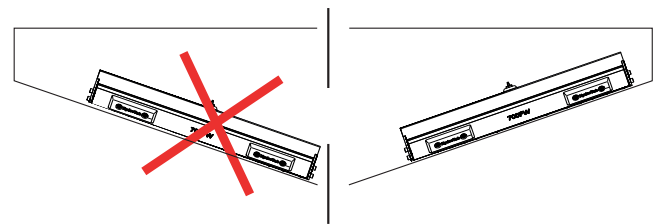

A good hint is that the closer the units are to the water line, the best the bank control of the boat will be.

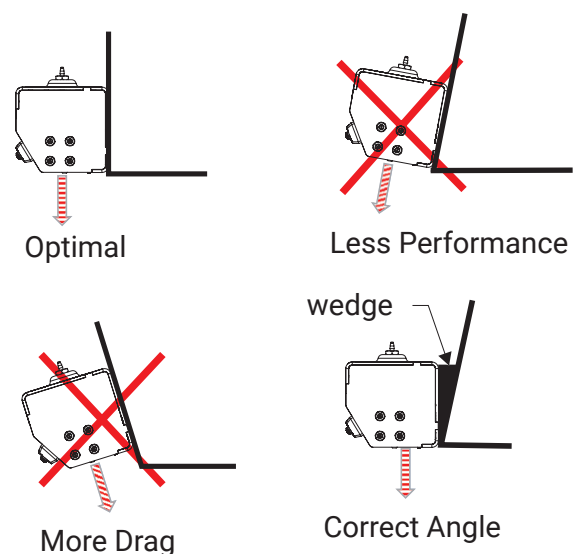

For maximum performance and less drag, install interceptors on the transom so blades deploy vertically. If transom is not vertical to water plane, correct the angle by using wedges or other means.

Attention:

The diameters of the holes in the templates are suggested for fiberglass boats. These dimensions are suitable for the supplied stainless steel screws that come with the units.

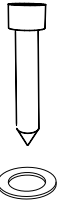

All screws must be placed with their respective washers.

The use of the 5,5 drill is suggested. The installer of the units must make sure that the 5,5 mm holes are suitable for the specific hull. The diameters of the drills that can be used are from 5,3 mm to 5,5mm (maximum) depending on the quality of the hull.

Interceptor Installation

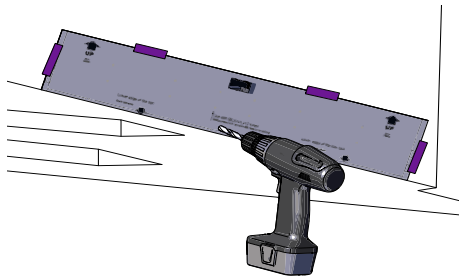

You will need

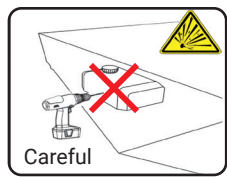
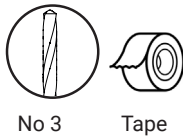

1

Drill all the pattern holes with 3mm bore without removing the pattern.

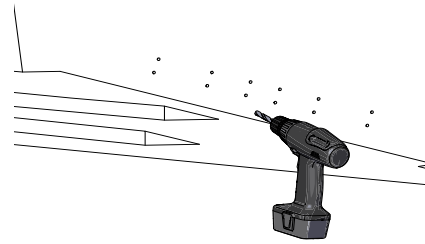

You will need

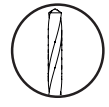

No 5,5

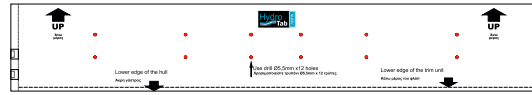

2

Remove the drilling pattern and drill according to the pattern instructions.

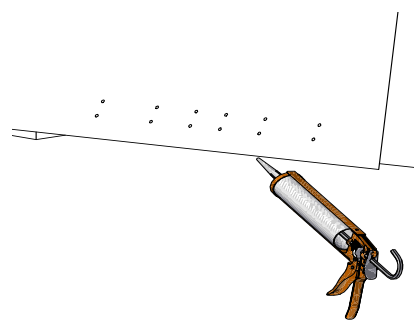

You will need



Spatula

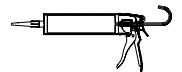

Sikaflex

3

Apply Sikaflex 291 to the holes and use a spatula to clean the excess glue from holes.

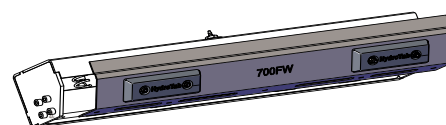
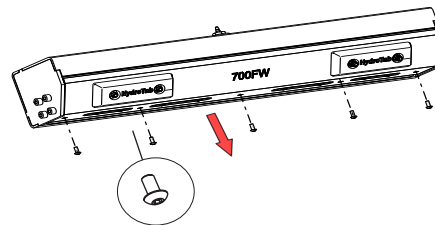

4

To open the cap you must ONLY remove the M5 screws.

Direct air supply

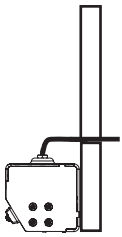

Indirect Air Supply Kit

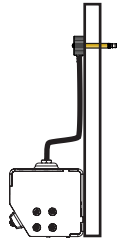

5

For Direct Air Supply: Advise the instructions.

For indirect Air Supply: Use the components included in the kit.

Indirect Installation

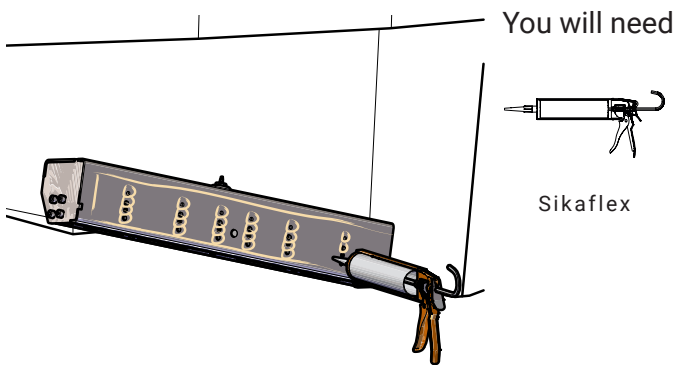

You will need

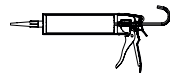

Sikaflex

6

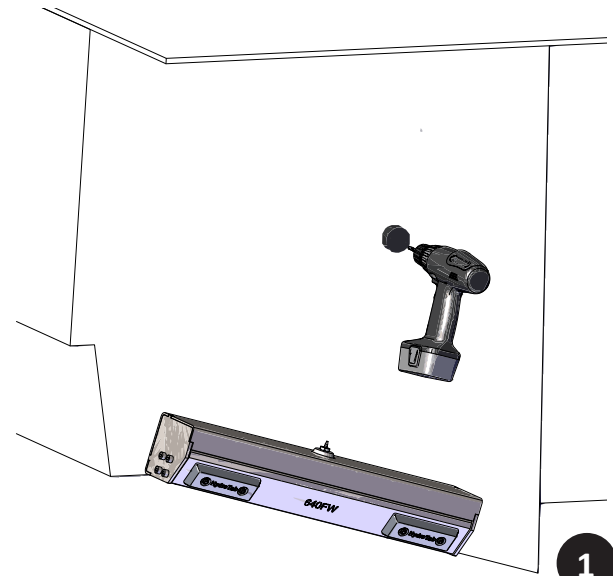

1

Apply Sikaflex to the interceptor.

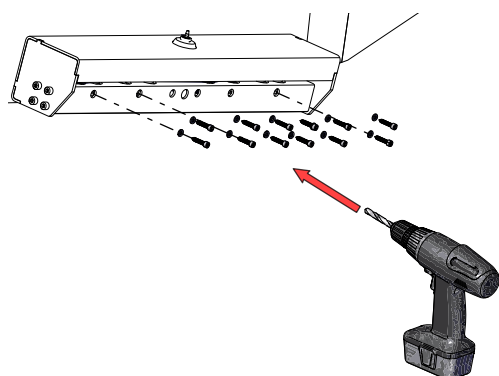

You will need



6,3x32 screws



M6 washer

7

Drill the transom, at the tube holder holes with a 12mm bore for the middle (tube passing through) hole and with a 3,8mm bore for the other two (mounting) holes.

Attention:

Before mounting the tube holder, apply Sikaflex (figure 2).

Mount the unit to the transom and close the cap.

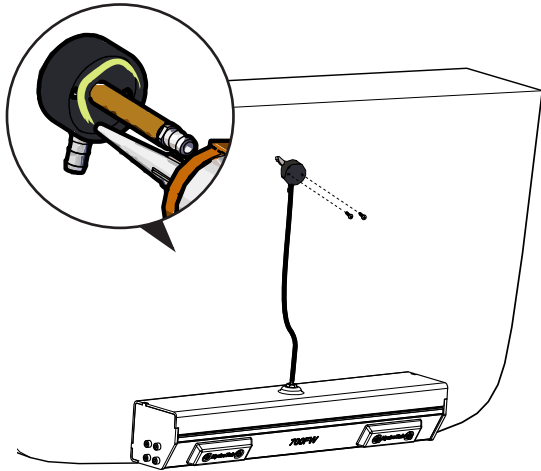

2

Mount the tube holder to the transom and connect the interceptor with the air unit

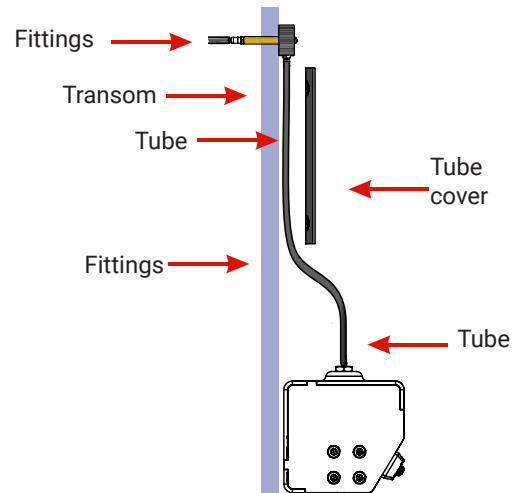

Air Supply:

Connect the interceptor with the Air Unit using the components given in the image.

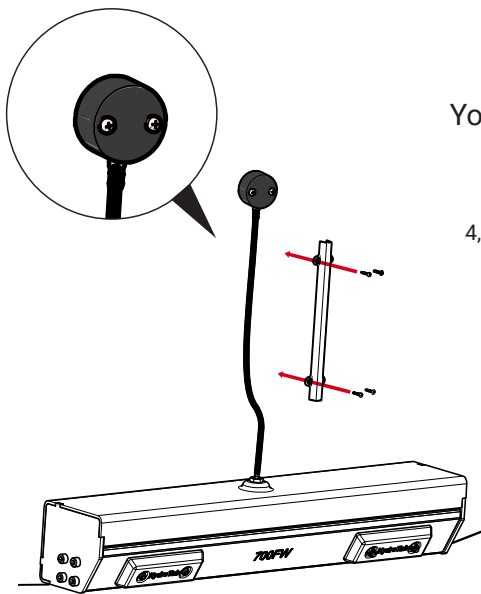

3

Drill the transom, at the tube cover holes with a 3mm bore.

FW Series Interceptor and Anode Mounting and Coating Instructions

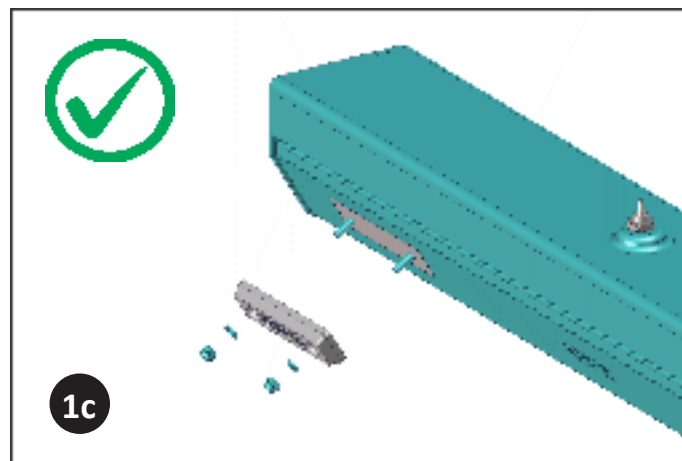
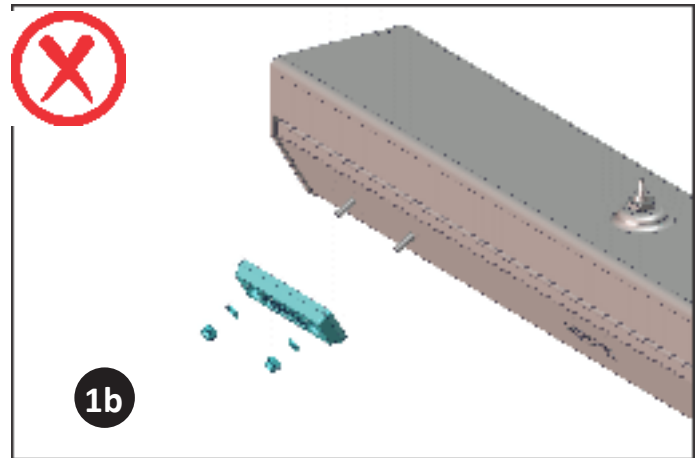
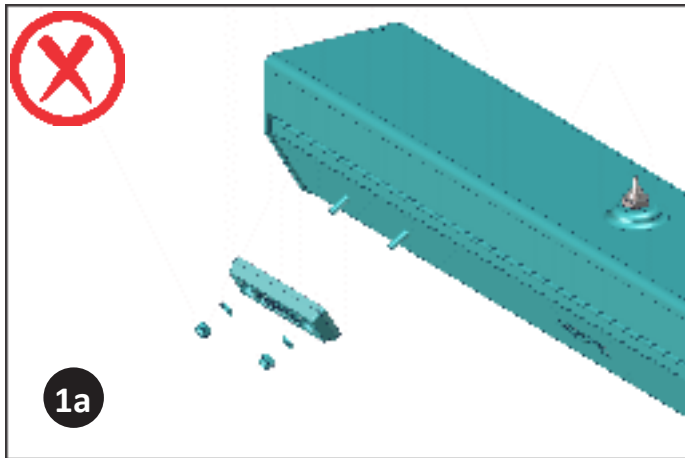

Note 1: You may apply protection coating on interceptor if you'd like so, but:

1. Do not apply coating on anodes
2. Do not apply coating on the area of interceptors which is in contact with anode (see Fig. 1a, 1b, 1c).

Note 2: When in brackish or fresh water, use Magnesium anodes instead of Zinc (Zinc anodes are pre-installed and they are appropriate only for sea-water).

Note 3: Check often condition of anodes and replace them when they lose about 50% of their mass. Life time of anodes cannot be easily predetermined because it is related to sea-water characteristics as well as other

Spare Parts and order information

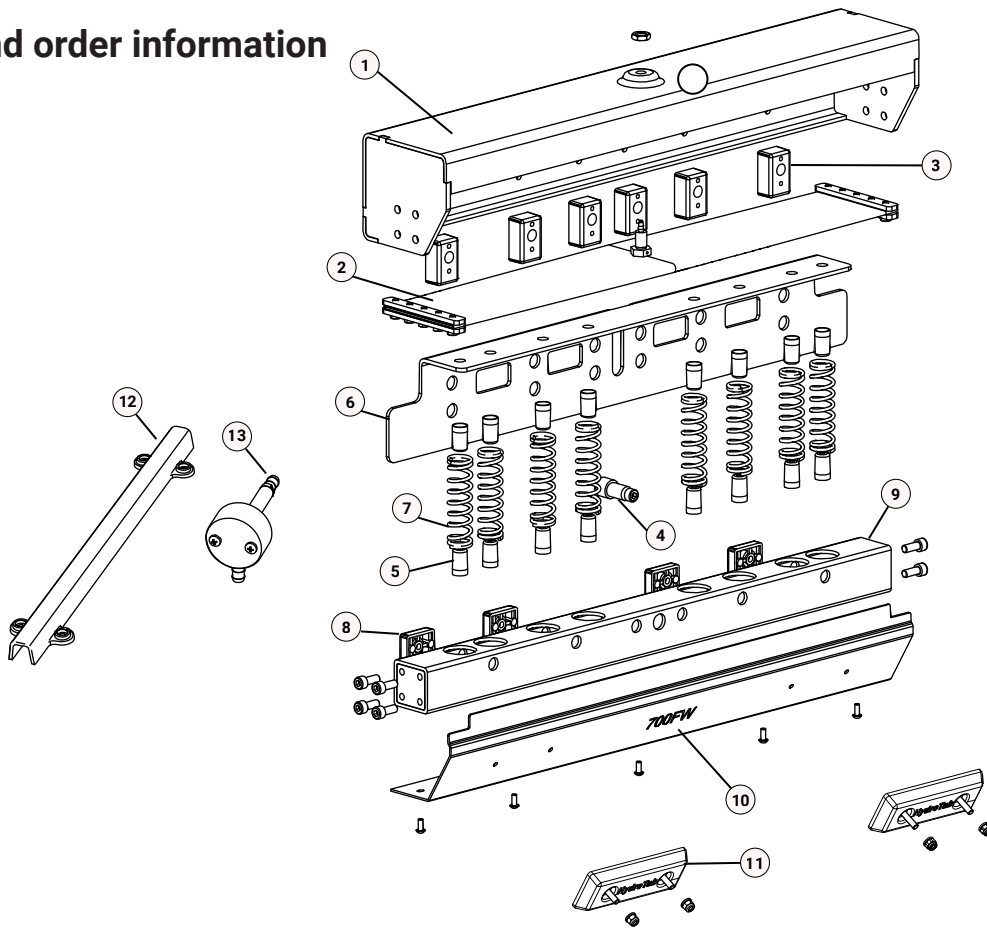

ID No	CODE				DESCRIPTION
	640 FW	700FW	800FW	1000FW	
1	ASM-00719	ASM-00401	ASM-00158	ASM-00160	Body
2	ASM-00815	ASM-00814	ASM-00087	ASM-00092	Inflatable tubular
3	GEN-00025				Plastic guides
4	REV-00427				Beam Spaser
5	GEN-00032				Spring support
6	LAS-00598	LAS-00459	LAS-00127	LAS-00269	Interceptor blade
7	SPR-00007				Spring
8	GEN-00018				Plastic guides
9	ASM-00720	ASM-00403	ASM-00155	ASM-00131	Bar
10	LAS-00595	LAS-00461	LAS-00125	LAS-00132	Cover
11	GEN-00540				Aluminum Anode
12	GEN-00634				TUBE COVER
13	ASM-01809				INDIRECT AIR SUPPLY KIT FW FERRETI
12	GEN-00571				TUBE HOLDER

Warranty Conditions

LS Series Interceptor units are covered by a 2-year Warranty. Recoil springs, electrical/electronic parts and devices come with a 2-year warranty. Anodes (consumables) are not included in the warranty. Hydrotab's warranty only covers the repair or replacement of spare parts.

System selections

It is the sole responsibility of the buyer to choose the correct system and even with Hydrotab's suggestion for a system, the overall responsibility is with the buyer.

Limited warranty

Provided that the system has been installed in accordance with the installation manual we provide, and no damage has been caused due to improper handling or practices, Hydrotab will replace any defective parts or parts that failed due to improper manufacturing within the applicable warranty period.

Hydrotab only covers the parts' replacement. Fitting or shipping costs are not covered by warranty.

Hydrotab will select if we will repair or replace any given part. Repaired or replaced products will assume the remainder of the warranty time and under no conditions will the full time of warranty be renewed.

Limited warranty periods

Limited warranty period is two years (2 years) from the product shipment from our premises.

Extended limited warranty period

It is provided in case:

- a) Hydrotab trim system is included as equipment of a newly purchased boat directly by from the boat-builder or his reseller.
- b) Hydrotab trim system has been purchased through a Hydrotab dealer.

The extended limited warranty period is valid for three (3) years from the shipping date, provided that the customer has downloaded, completed and submitted the online registration form within one month (30) days from the purchase in the following url.

<https://www.hydrotab.gr/product-registration>

In case the dealer sells separate units of Interceptors, Air Units and Controllers that constitute a full system that is not initially sold (as a complete system) by Hydrotab, the dealer has the responsibility to provide the separate Serial Numbers for the Interceptors, Air Units and Controllers and guide the end user for the proper registration of his serial numbers for the extended warranty to be valid.

The authorized dealer is responsible for the product's service.

For any services or spare parts requirements and replacements during warranty period, the original invoice is necessary to be presented.

For the replacement of any part of the system (interceptors, Air Unit, any controller etc.) under warranty, the replaced parts must be returned to Hydrotab Marine Engineering for inspection, otherwise warranty is not valid.

Cost of dismantling - assembly and spare parts transportation is borne by the user.

The warranty does not foresee, under any circumstances, replacement of the whole Hydrotab system.

What is not covered by the warranty:

Damage caused by the lack or non-replacement of worn anodes (for BT, FW, TS Series).

Damage caused by improper installation and use not consistent with the manual.

Damage with external visible deformation of the product caused by misuse of the user or other external causes.

Damage to any component caused during transportation, installation or repair from non-authorized personnel.

Conversions or modifications made after the initial sale.

N. Triantafyllis Ltd (Hydrotab Marine Engineering) is not liable for any incidental, indirect or consequential damages or losses, including, without limitation: travel expenses, transport, lifting and hauling, costs, loss of income, loss of time, loss of property, loss of profits, personal injury or damage of any products, different from those that the company distributes. Any further (except the above mentioned) commitment of the intermediate dealer regarding the sale terms or servicing of Hydrotab products does not create any liability of our company.



www.hydrotab.gr/product-registration

Congratulations for your
new Hydrotab system!

Please register to activate the
extended limited warranty

